

LOGSET Shear Head

SH38



SH38 provides the best performance and cost-effectiveness on the market. Reliable, productive and easy to maintain, the SH38 fulfils all the user's requirements in the toughest of conditions.

The SH38 suits to various forest operations from thinnings to clear cuts thanks to its compact size and strong design. The shear head can be mounted on track based machines from 18 to 25 tons. The optimal working diameter range extends from 5 to 38 cm when cutting hardwood.

As an option, a bunch processing unit can be mounted for multi-stemming applications.

With a compact design the SH38 can easily approach trees. The innovative system of the SH38 is based on overlapping shear blades that ensure an excellent cutting result of both large and small diameter trees and are nearly maintenance-free. The separate control valves for the arms, the shear unit and the bunch processing unit (option) improve the timing of the operations and decrease the felling rotation time.

The shear unit is mounted with two strong hydraulic cylinders operating at 300 bars of pressure.

Regarding cost-effectiveness, the shear head SH38 is number one on the market.

NEW DIMENSION

LOGSET
BIO ENERGY

LOGSET Shear Head

SH38

DIMENSIONS

Width	mm	1280
Length	mm	1500
Height	mm	1330
Weight	kg	1550

CUTTING

Max. cutting diameter	mm	450
Opt. cutting diameter	mm	380
Opening of the blades	mm	910

HYDRAULIC SYSTEM

Maximum pressure	bar	300
Flow required for optimal prod.		180 l/min

GRAPPLE

Max. opening	mm	1050
Max. depth	mm	550

RECOMMENDED BASE MACHINE SIZE

Tracked base	t	18-25
--------------	---	-------

OPTIONAL EQUIPMENT

Bunch processing unit	kg	270
-----------------------	----	-----

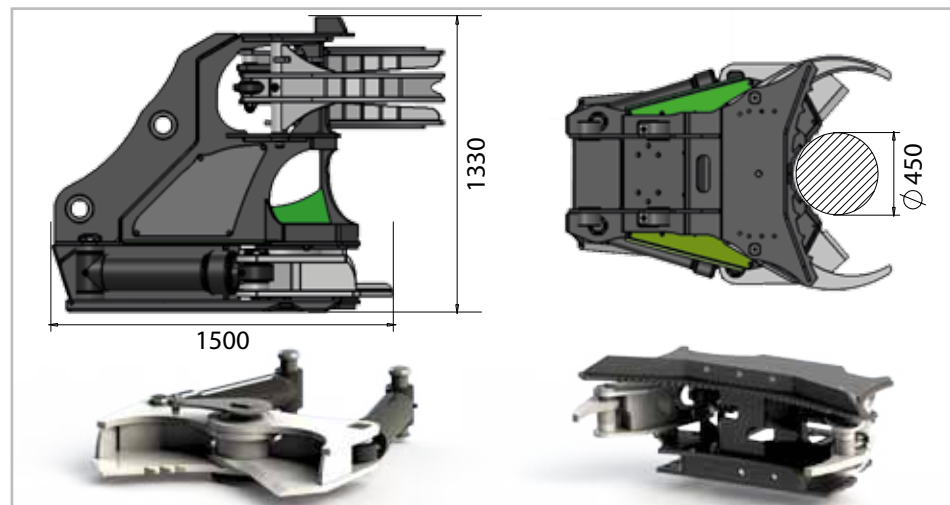

+ SEPARATE CONTROL VALVES

- Cutting unit
- Grapple unit
- Bunch processing unit

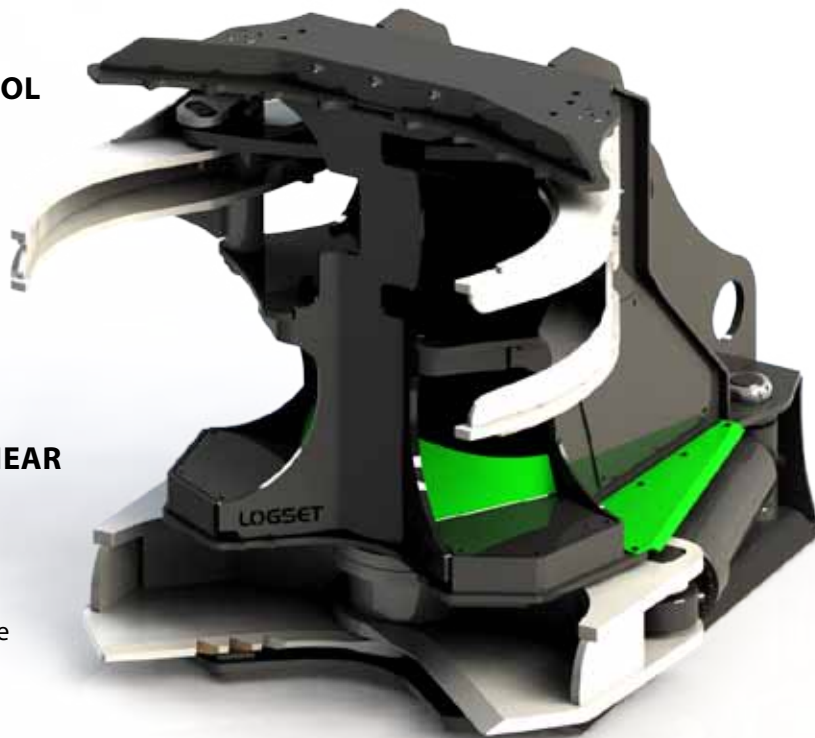

+ OVERLAPPING SHEAR BLADES

- Strong
- Excellent cutting result
- Nearly maintenance-free and easy service

+ STRONG AND COMPACT

- Boom mounting close to the grapple and the cutting unit
- Hydraulic hoses and cylinders protected inside the frame
- Good visibility to the grapple and cutting unit

+ POWERFULL

- 45 t cutting power
- 2 massive hydraulic cylinders of 300 bar each

Check our videos!



Logset Oy
Hännisentie 2
FI-66530 Koivulahti
FINLAND
Tel. +358 10 286 3200
Fax +358 6 210 3216

Shear Heads range 03/15 - EN
We reserve the right to make changes without prior notice.
All technical specifications are for guidance only.
The pictures and diagrams do not always show standard versions of the shear heads.
Copyright Logset Oy.

LOGSET
BIO ENERGY

www.logsetbioenergy.com